

Christophe QUEVAL

GENÈSE

- pour Clarinette et Piano -

- opus 4 -

(1989, rév. 1993 – durée : 10'30)

GENESE

-pour clarinette et piano-

I.

C. QUEVAL, Opus 4
(1989, rév. 1993)
durée : 10' 30

Lent et soutenu (♩ = 50)

Clarinetto (en Si b)

Piano

8vb

Clar.

P^o.

8vb

Clar.

P^o.

8vb

Clar. 

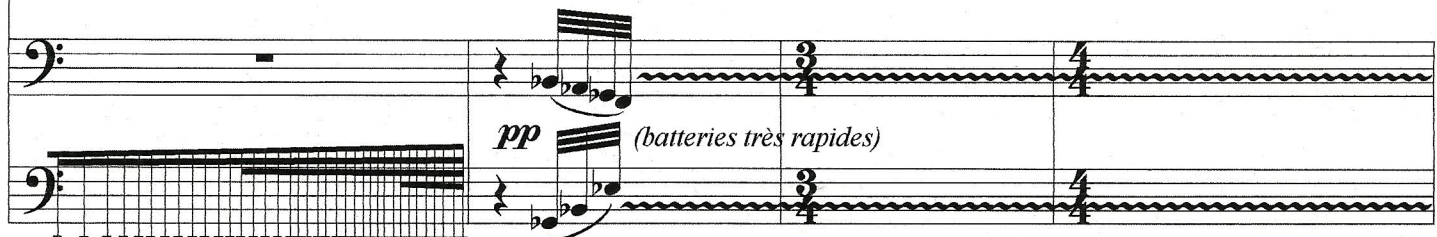
P.^o. 

pp (batteries très rapides)

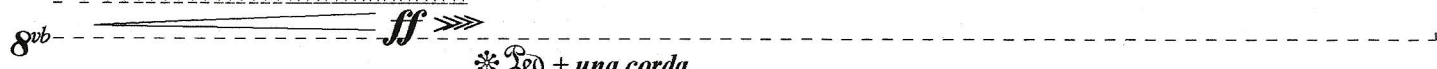
ff 

ff * Led. + una corda

Clar. 

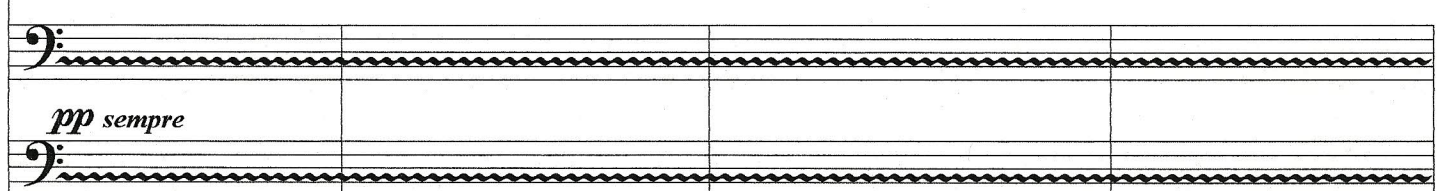
P.^o. 

pp sempre

sf *p* *mf*

pp 

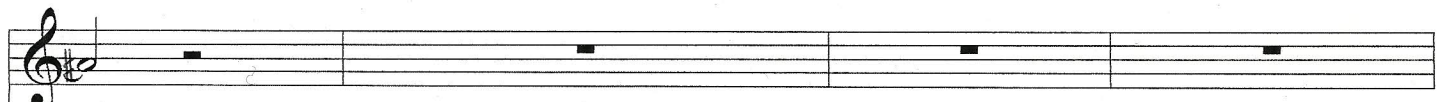
Clar. 

P.^o. 

mf

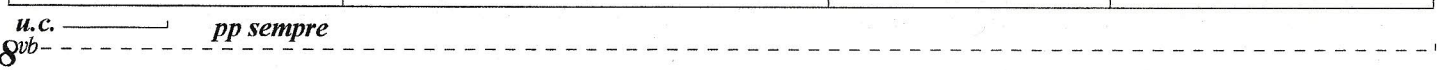
pp sempre 

u.c. *pp sempre*

Clar. 

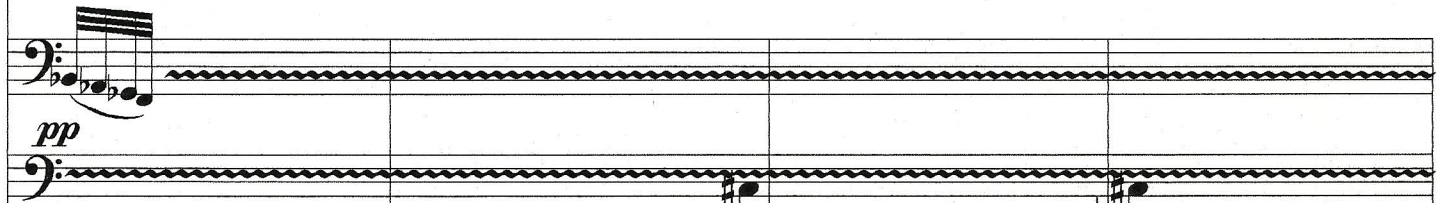
P.^o. 

pp

pp *mp* *ff* *p*

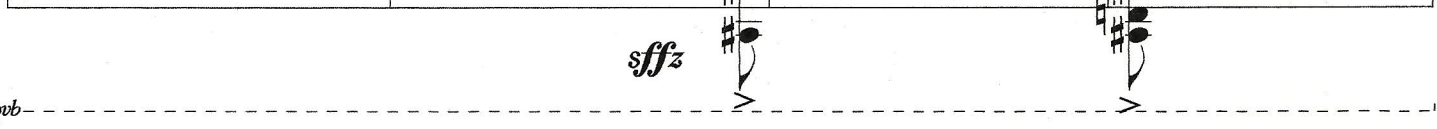
sffz 

sffz

Clar. *p* *pp* *fff* (long)

P^o. *ff* *p* *Ped.

8vb

Detailed description: This system shows the first system of music. The Clarinet part is in treble clef, 3/4 time, with dynamics *p*, *pp*, and *fff*. A long note is marked "(long)". The Piano part consists of two staves (treble and bass clefs). The bass clef has a wavy line and a *ff* dynamic. The treble clef has a *p* dynamic and a triplet of eighth notes. A dashed line labeled "8vb" is below the piano part. A *Ped. symbol is at the end of the piano part.

II.

Clar. *f* *mf*

P^o. *pp* *fff* *mf* (long)

8vb

♩ = 84

*Ped.

Detailed description: This system shows the second system of music. The Clarinet part is in treble clef, 3/4 time, with dynamics *f* and *mf*. The Piano part consists of two staves. The bass clef has a wavy line and a *pp* dynamic. The treble clef has a *fff* dynamic and a *mf* dynamic. A long note is marked "(long)". A tempo marking "*♩* = 84" is above the clarinet part. A *Ped. symbol is at the end of the piano part.

Clar. *mp* *f* (avec du souffle)

P^o. *ff* *mp* *mp*

8vb

15^{ma}

*Ped.

Detailed description: This system shows the third system of music. The Clarinet part is in treble clef, 3/4 time, with dynamics *mp* and *f*. A phrase is marked "(avec du souffle)". The Piano part consists of two staves. The bass clef has a wavy line and a *mp* dynamic. The treble clef has a *ff* dynamic and a *mp* dynamic. A 15-measure phrase is marked "15^{ma}". A *Ped. symbol is at the end of the piano part.

Clar. *mp*

P^o. *pp* *ff* *p* *expressif* (laissez résonner)

8vb

*Ped.

Detailed description: This system shows the fourth system of music. The Clarinet part is in treble clef, 3/4 time, with a *mp* dynamic. The Piano part consists of two staves. The bass clef has a wavy line and a *pp* dynamic. The treble clef has a *ff* dynamic and a *p* dynamic. A phrase is marked "(laissez résonner)". A *Ped. symbol is at the end of the piano part.

Clar. *p* \curvearrowright *f* \curvearrowright *mf* \curvearrowright *sf*

P^o. *pp* \curvearrowright *mp* \curvearrowright *pp*

(batteries très rapides)

Red. + una corda \curvearrowright ** Red.*

Clar. *f* \curvearrowright *poco mf* \curvearrowright *p* \curvearrowright *mf* \curvearrowright *p*

P^o. *poco mf* \curvearrowright *p* \curvearrowright *mf* \curvearrowright *p*

** Red.* \curvearrowright ** Red.*

Clar. *mp* \curvearrowright *pp* \curvearrowright *ff* \curvearrowright *mf*

P^o. *ff* \curvearrowright *pp*

** Red.*

Clar. *f* \curvearrowright *mp*

P^o. *f* \curvearrowright *p* \curvearrowright *mf* \curvearrowright *fff* *(long)*

** Red.* \curvearrowright ** Red.* \curvearrowright *u.c.* \curvearrowright ** Red.* \curvearrowright *gub.*

III . Très Vif, au moins ♩=144

P^o.

f 8^{vb}

This system shows the first two measures of the piano accompaniment. The right hand has whole rests. The left hand plays a rhythmic pattern of eighth notes with a dynamic marking of *f* and an 8^{vb} (8va below) marking.

P^o.

8^{vb}

This system shows measures 3 and 4. The right hand has whole rests. The left hand continues the eighth-note pattern with a dynamic marking of *f* and an 8^{vb} marking.

P^o.

sf (en dehors)

8^{vb} (avec peu de pédale)

This system shows measures 5 and 6. The right hand has whole rests. The left hand plays chords with a dynamic marking of *sf* and the instruction "(en dehors)". An 8^{vb} marking is present. The instruction "(avec peu de pédale)" is written below the system.

P^o.

15^{ma}

sf *f*

8^{vb}

This system shows measures 7 and 8. The right hand has whole rests. The left hand plays chords with a dynamic marking of *sf* and *f*. A 15^{ma} (15th measure) marking is above the first measure. An 8^{vb} marking is present.

Clar.

Un peu retenu
flatt 3

mf

15^{ma}

sffz

8^{vb}

This system shows measures 9 and 10. The Clarinet part has a dynamic marking of *mf* and the instruction "Un peu retenu" with a wavy line and a triplet of three notes. The piano accompaniment has a dynamic marking of *sffz*. A 15^{ma} marking is above the first measure. An 8^{vb} marking is present.

A Tempo

Clar. *f* 3

P^o. *f* *sf* 8^{va}

Clar. *mf* 3 *f* *flatt* 3

P^o. *poco f* 6 *sf* 8^{va} Gliss

Clar. 3:5 3

P^o. *f* 8^{va} 15^{ma} 8^{va}

Clar. *sf* *flatt* 5

P^o. 8^{va}

Clar.

P°

15^{ma}

sfz *mf*

Clar.

P°

f *sfz*

Clar.

P°

f *ff*

Clar.

P°

f *pva*

Clar. *f* sempre *mf*

P^o. *p subito*

8^{vb}

Clar. *ff* *mf* *f*

P^o.

8^{vb}

Clar. *f* *ff*

P^o. *8va* *mf* *f*

8^{vb}

Clar. *fff*

P^o. *15^{ma}* *fff*

8^{vb}

Clar. *flatt*
mf *ff*

15^{ma}

P^o. *8vb*

Clar. *sffz* *ff*

15^{ma}

P^o. *8vb*

Clar.

15^{ma}

P^o. *8vb*

IV. ♩ = 60 solo, ad libitum

Clar. *ff* *pp subito* *(long)* *ff*

P^o. *(laissez résonner)*

Clar. *flatt* *p* *mp* *pp en écho* *poco sf*

Clar. *p* *f* *mf* *sf* *f*

Clar. *mp* *mf* *p* *f* *ff*

Clar. *mf* *sffz* *pp pâle et immobile*

V. Très Lent (♩=46)

Clar. *pp*

p^o. *pp*

Red. + una corda



Clar. *p* *6* *3*

P^o. *f* *pp* *f* *pp* *sf* *8vb*

Red. + una corda **Red. (simile)*

Clar. *mp* *f subito*

P^o. *p* *f* *ff* *f* *pp* *p* *sf* *8vb*

8va

Clar. *mf* *pp* *sf*

P^o. *pp* *f* *f* *pp* *sf* *8vb*

Clar. *pp* *f*

P^o *pp* *p* *sf* *f*

8va

8vb

Clar. *p* *ff*

P^o *p* *sfz* *f*

8va

8vb

Clar. *mf* *p* *pp* *sf*

P^o *pp* *sf* *pp* *f*

8va

8vb

Clar. *mp* 3 3 5

P^o *p profond* *mf* 8^{va} 8^{vb}

sf 8^{vb}

Clar. *Cédez...* *mf* 5 3 5

P^o *pp* *f* 15^{ma} 8^{vb}

pp *f* 8^{vb}

Clar. *poco f* *mp* *morendo*

P^o *pp* *préparez les harmoniques* *m.dr.* *laissez longuement résonner les harmoniques* *sffz sec* *Reo.* 8^{vb}